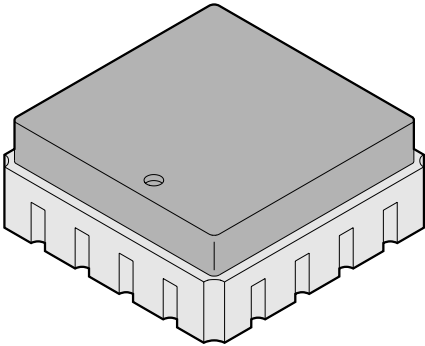

LCC-16C-F01

EIAJ code : *QFN016-G-S250-1

<p>16-pad ceramic LCC</p>  <p>(LCC-16C-F01)</p>	Lead pitch	50 mil
	Package width × package length	250 × 250 mil
	Sealing method	Frit seal

16-pad ceramic LCC
(LCC-16C-F01)

*Shape of PIN NO.1 INDEX : Subject to change without notice.

